

ROTEX® | GROUP

ROTEX® BM&M

We offer several enhanced options for our machines...

While all of our machines have been carefully designed to suit your requirements, we understand that every company and industry is different and in some instances you may require additional functionality from your chosen machine.

Therefore, we have introduced a range of upgrades and additional options to provide you with a more customized solution should you require it.

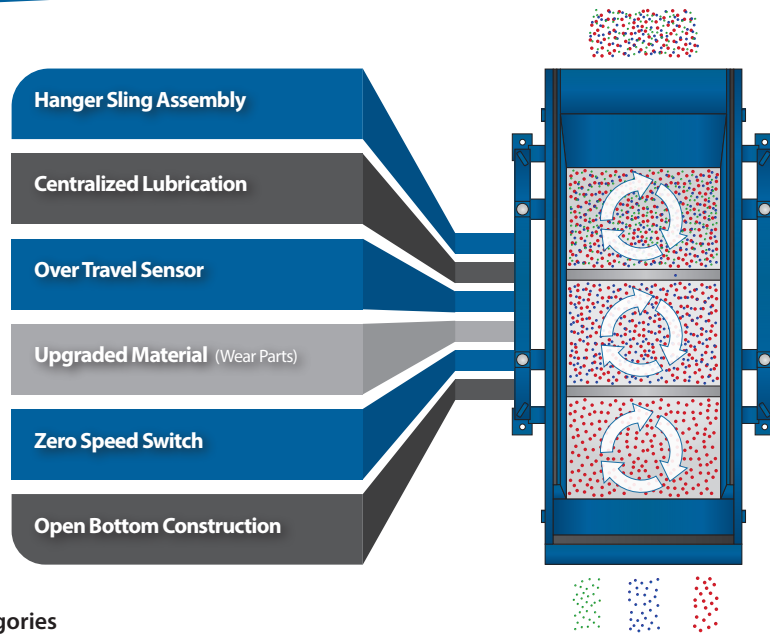

Option Categories

SAFETY

MAINTENANCE FRIENDLY

DURABILITY

➤ Hanger Sling Assembly **SAFETY**

Additional Support Option available to ensure no catastrophic damage to your equipment in the event of double hanger failures.

➤ Centralized Lubrication System **MAINTENANCE FRIENDLY**

System designed to allow for greasing of the U-Joints by an operator without requiring a machine shut down period.

➤ Over Travel Sensor **SAFETY**

To detect when equipment is traveling outside the programmed range of motion and implement machine shutdown.

➤ Upgraded Material for Wear Parts **DURABILITY**

A wide range of material upgrades can be provided to ensure your common wear components have a longer life span.

➤ Zero Speed Switch **SAFETY**

To detect when the machine has its regular operation disrupted or has reached a zero speed state.

➤ Open Bottom Construction **MAINTENANCE FRIENDLY**

Elimination of fines pan to eradicate blinding of fines material that can freeze or bond to metal in changing weather conditions.

Installation Options:

- Suspended Construction Option
- Sub-base Stand for Installations
- Support Stand



Sizes and Specifications

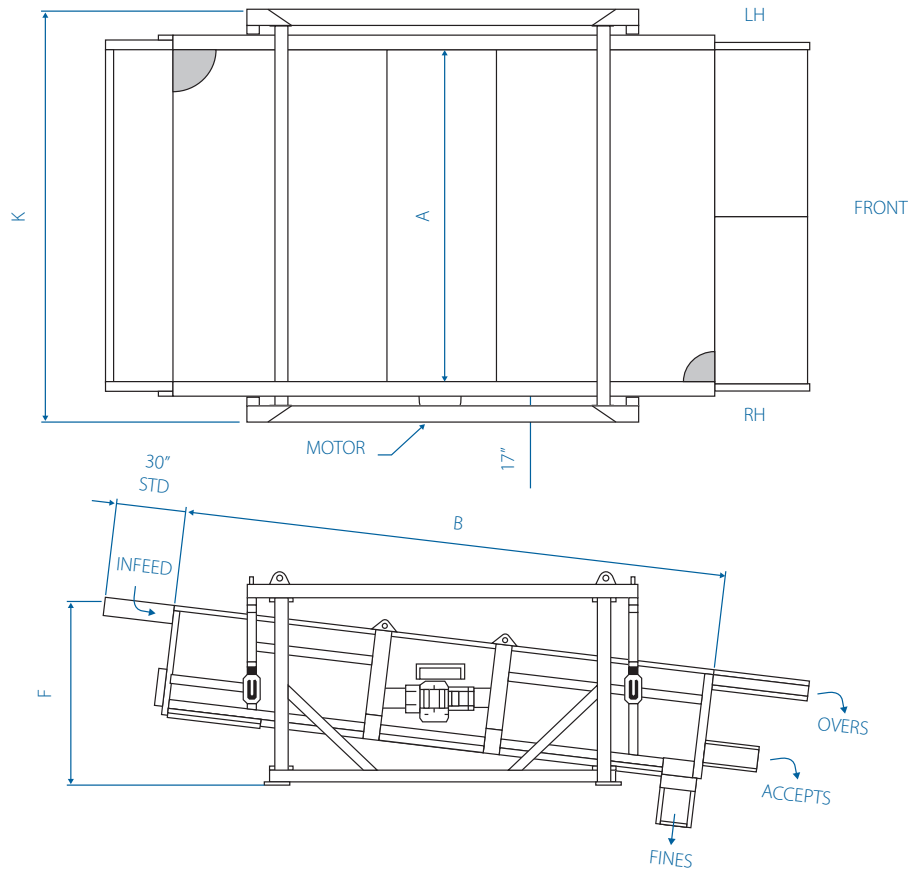

MODEL											
A x B	Area [ft ²]	Area [m ²]	Power [HP]	Power [KW]	F [in]	F [cm]	K [in]	K [cm]	Weight [lb]	Weight [kg]	
3' x 8'	24	2.23	5	3.7	59	150	64	163	3,500	1,588	
3' x 10'	30	2.79	5	3.7	61	155	64	163	3,700	1,678	
4' x 8'	32	2.97	5	3.7	59	150	76	193	4,000	1,814	
4' x 10'	40	3.72	6	4.5	61	155	76	193	4,200	1,905	
4' x 12'	48	4.46	5	3.7	62	157	76	193	4,600	2,087	
5' x 10'	50	4.65	5	3.7	64	163	92	234	5,200	2,359	
5' x 12'	60	5.57	5	3.7	67	170	92	234	5,900	2,676	
6' x 10'	60	5.57	5	3.7	64	163	104	264	6,200	2,812	
6' x 12'	72	6.69	5	3.7	67	170	104	264	6,600	2,994	
6' x 14'	84	7.80	5	3.7	70	178	104	264	6,900	3,130	
6' x 16'	96	8.92	7.5	5.6	73	185	104	264	7,300	3,311	
7' x 10'	70	6.50	5	3.7	64	163	116	295	6,700	3,039	
7' x 12'	84	7.80	7.5	5.6	67	170	116	295	6,900	3,130	
7' x 14'	98	9.10	7.5	5.6	70	178	116	295	7,400	3,357	
7' x 16'	112	10.41	7.5	5.6	73	185	116	295	7,900	3,583	
8' x 10'	80	7.43	7.5	5.6	64	163	128	325	7,000	3,175	
8' x 12'	96	8.92	7.5	5.6	71	180	128	325	7,500	3,402	
8' x 14'	112	10.41	7.5	5.6	73	185	128	325	8,000	3,629	
8' x 16'	128	11.89	10	7.5	77	196	128	325	8,300	3,765	
8' x 18'	144	13.38	10	7.5	79	201	128	325	8,700	3,946	
8' x 20'	160	14.86	10	7.5	81	206	128	325	9,200	4,173	
10' x 12'	120	11.15	7.5	5.6	74	188	156	396	9,100	4,128	
10' x 14'	140	13.01	10	7.5	79	201	156	396	9,500	4,309	
10' x 16'	160	14.86	10	7.5	81	206	156	396	9,900	4,491	
10' x 18'	180	16.72	10	7.5	84	213	156	396	10,600	4,808	
10' x 20'	200	18.58	10	7.5	85	216	156	396	11,100	5,035	
12' x 20'	240	22.30	10	7.5	85	216	180	457	13,200	5,987	
13' x 20'	260	24.15	15	11.2	85	216	192	488	14,000	6,350	
13' x 20' JB	260	24.15	20	14.9	97	246	192	488	15,400	6,985	